

Mine Electric Locomotive Design and Simulation Study of Anti-skid Braking System

Chakradhar karan¹, Swagatika Satapathy²

¹ Department of Electrical & Electronics Engineering, Gandhi Engineering College, Odisha, India

² Department of Electrical & Electronics Engineering, Gandhi Institute For Technology, Odisha, India

ABSTRACT: The motor vehicle as the research object, designed a new scheme of the brake, hydraulic disc brake used in motor vehicle design, anti-skid brake system for the control, PID control and non motor vehicle braking system for modeling and Simulation of the logic threshold value in MATLAB/Simulink. The simulation results show that the motor vehicle braking effect of motor vehicle use of anti slip brake system was better than that of non slip system; using PID braking system control algorithm is better than using logic threshold control braking system.

Keywords: motor vehicle, disc brake, PID control, MATLAB/Simulink

I. INTRODUCTION

Motor vehicle plays a very important role in coal transportation, because the existing motor vehicle braking system is relatively backward, the braking distance is too long, and easy to lock, seriously affect the transportation efficiency and motor vehicle safety. To solve this problem, this paper designs a new scheme of the brake, hydraulic disc brake braking system used in motor vehicles, and the addition of the anti lock braking system, it not only shortens the response time of the braking system, but also improve the utilization rate of adhesion coefficient between wheel and rail. This paper also carries on the simulation analysis of the anti lock braking system, braking performance comparison of different anti lock control system, to provide reference for the selection of each type of motor vehicle braking control system suitable for improving, bring the important significance of motor vehicle transportation efficiency and safety.

II. DESIGN OF BRAKE ACTUATING MECHANISM FOR ELECTRIC LOCOMOTIVE

A new type of braking scheme is designed. The hydraulic disc brake is applied to the electric locomotive. In order to refit the existing electric locomotive, the brake disc is installed at one end of each reducer's middle speed shaft. In order to reduce the adverse effects of braking torque on each part of the gear box during braking, two sets of brake caliper assemblies are arranged on the brake disc and symmetrically arranged. The installation details of the brake are shown in figure 1.



Figure 1: The Installation Details of the Brake

III. ANTI LOCK BRAKING SYSTEM PRINCIPLE AND DESIGN

Anti Lock Braking System Principle

The motion state of anti lock function of the system is analyzed and the locomotive wheel, through the booster, the wheel cylinder pressure and decompression operation, to adjust the braking torque of the brake, the wheel slip rate has been near optimal value fluctuations, in order to obtain the highest braking torque. As shown in Figure 2, said the working principle of anti lock braking system, brake in the initial state, pressure regulation unit components are not electricity, normally open solenoid valve 4, normally closed solenoid valve 5 and the motor 12 is reset, at this time, as with conventional brake oil pressure, brake master cylinder 2 often open the

high-speed switch electromagnetic valve 4 into 6 wheel brake cylinder, wheel cylinder piston pushes the friction pads pressure in the brake disc 7, then the implementation of locomotive brake.

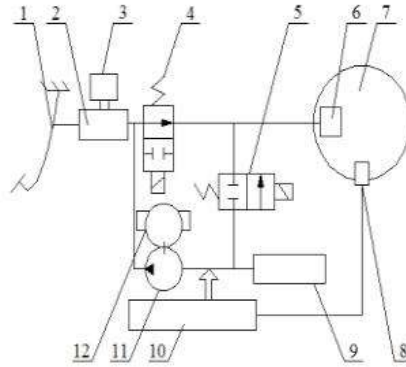

Figure 2: Anti Lock Braking System Schematic

In the braking process, to obtain real-time state information using wheel motion controller 10 wheel speed sensor 8, and compared with the reference speed, when a wheel slip rate exceeds the set value, the need to implement decompression operation on the wheel. When the creep rate of the wheel set is reduced to the set range, the pressure maintaining operation is carried out on the wheel set. When the creep rate of the wheel set decreases below the set range, it is necessary to perform pressurization operation on the wheel cylinder. Anti lock braking system is through the booster - wheel cylinder pressure - relief, this cycle of action, to adjust the braking torque of the brake disc, to ensure that the wheelset creep rate at the best value near the fluctuation, provide larger braking force and motor vehicle.

Design of Anti Lock Braking System

In order to improve the reliability and safety of the braking system, the dual loop braking system is adopted, and the two circuits are connected with two high pressure chambers of the master cylinder, each circuit can act separately. Unlike the braking system of the car, the motor vehicle has 2 brake discs, each of which is mounted on two running mechanisms, and each brake disc is provided with 2 brake caliper assemblies. Here, put forward two kinds of shunt system as shown in Figure 3: a scheme, each loop control of a brake disc; the two loop control scheme of B, cross the two brake disc.

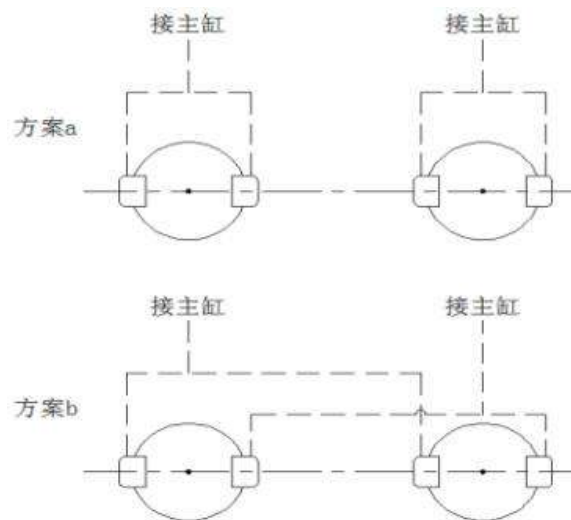

Figure 3: Braking Shunt Scheme

The two brake shunt schemes shown in Figure 3 do not make any difference in normal braking, but when one of the brake lines is damaged, the two options will vary considerably. For A, only when the front wheel brake wheel is intact, in order to provide greater braking force, and when the rear wheel is provided as, braking force is small, but the speed shaft of the gear box scheme of stress in good condition, will not be affected by the additional brake moment; for B, no matter where a brake line is damaged, can always control the front and rear wheel brake pedal force, but unchanged in the case of braking force than under normal conditions can be reduced by half, however, by increasing the pedal force to achieve the same effect with the normal braking condition, but the speed of shaft force will become worse.

Based on the design of the braking system of motor vehicles, in order to improve the utilization rate of adhesion coefficient between wheel and rail with anti lock braking system for the two different, because, on the contact state and the track so for a greater degree of increase the brake friction on two separate control of must. To sum up, the A scheme is used to arrange the brake line.

Anti Lock Braking System Algorithm

At present, the control algorithms used in the anti-skid control system include logic threshold control, PID control and so on. The logic threshold control method is a kind of control method based on experience value. This method does not need to involve the specific mathematical model of the system, so it is easy to realize the control of nonlinear system, so it is widely used. The advantage of this method is that the control is simple and the calculation is small and easy to implement. Now, this control algorithm is adopted in the anti slip system of automobile. PID control method is in process control, according to the ratio of deviation (P), integral (I) and differential (D) to control, the most widely used. The utility model has the advantages of simple principle, easy realization, wide application range, independent control parameter, simple parameter selection, and the like.

IV. ESTABLISHMENT OF ABS MODEL

Vehicle Dynamics Model

Mine electric locomotive has two sets of wheels, because the main research is mine electric locomotive braking system, in order to simplify the problem, use single wheel model. The force acting on the single wheel is shown in figure 4.

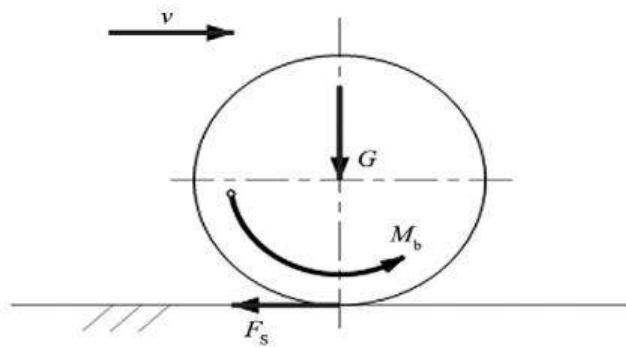

Figure 4: Single Wheel Force

Kinetic equation for:

$$\dot{\omega} = (F_s R - M_b) / I \quad (1)$$

$$F_s = \mu N \quad (2)$$

Where ω is wheel angular speed, F_s is wheel longitudinal friction force, R is wheel radius, M_b is braking torque, I is wheel inertia, and μ is longitudinal adhesion coefficient between wheel and rail, N is support force. According to formula (1) (2), the vehicle dynamics model built in Simlink is shown in figure 5. Its input is the longitudinal adhesion coefficient and braking torque between wheel and rail, and the output is wheel angular speed, braking distance and vehicle speed.

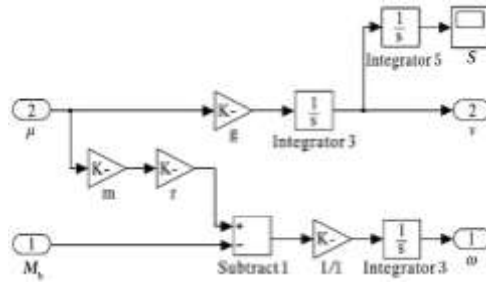

Figure 5: Vehicle Dynamics Model

Brake System Model

The brake system mainly consists of two parts, the brake and the drive mechanism, so it is necessary to establish the two parts of the model. The electric locomotive used in this paper adopts pneumatic transmission system to control the brake by controlling the conduction of the solenoid valve. The brake mainly controls the braking torque. In simulation, assume that the original elements used in the brakes are ideal.

$$M_b = Kp$$

Where M_b is the brake torque of the brake, K is the braking factor of the brake, and P is the output pressure of the drive system.

The transfer function is:

$$\frac{K}{sTs + 1}$$

Set the T in the transfer function to 0.01 and K to 100. The brake system model established according to formula (3) (4) is shown in figure 6.

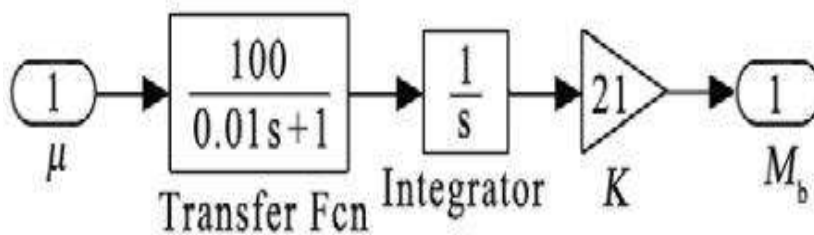

Figure 6: Brake System Model

Control System Model



Figure 7: Logical Gate Limit Control Module

In this module, we can use C language programming, threshold settings, the control parameters of the slip rate, threshold is 0.2.

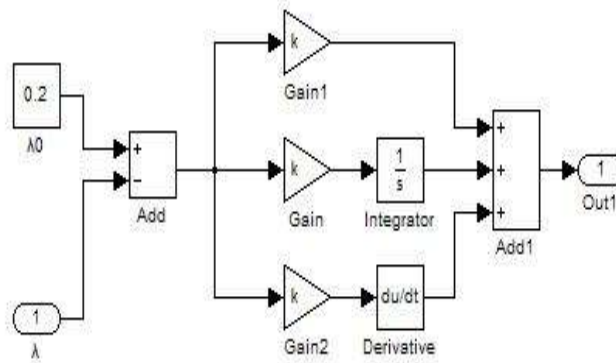

Figure 8: PID Control Module

The parameters such as proportion, link, integral link and differential link are 25, 0.1 and 10 respectively.

V. SIMULATION ANALYSIS OF ANTI LOCK BRAKING CONTROL SYSTEM

In order to verify the validity of the anti-skid braking system of electric locomotive, the anti-skid braking system with no anti-skid braking control, logical threshold control and PID control is simulated according to the model mentioned above. From the beginning. The speed is 8 m/s, and the simulation results are shown in Figure 9 ~ 11, respectively. Fig. 9 is the simulation result of the braking distance of the mine electric locomotive under the 3 different control algorithms. From Figure 9 shows that the braking distance of no motor vehicle antiskid braking control is the longest, 14.68 m; the logic threshold control of motor vehicle braking distance and braking distance is 12.45 m; the motor vehicle PID control is the shortest, 4.50 m.

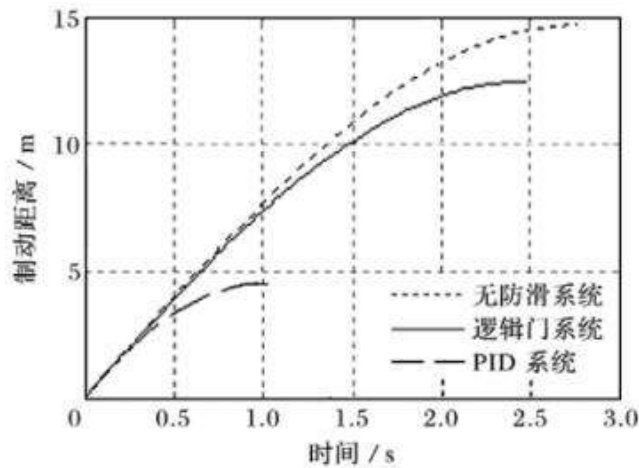
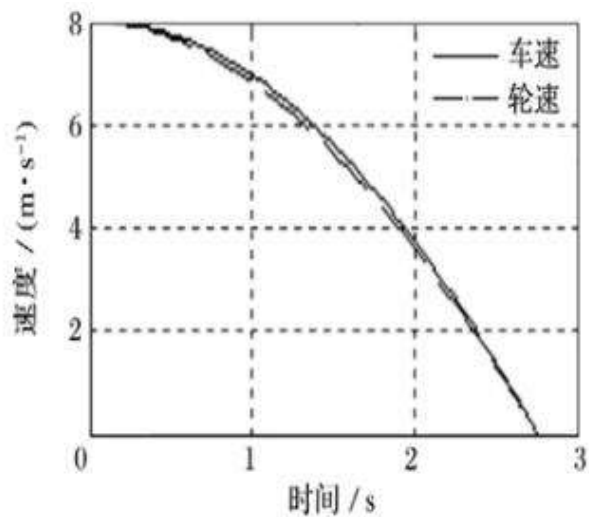
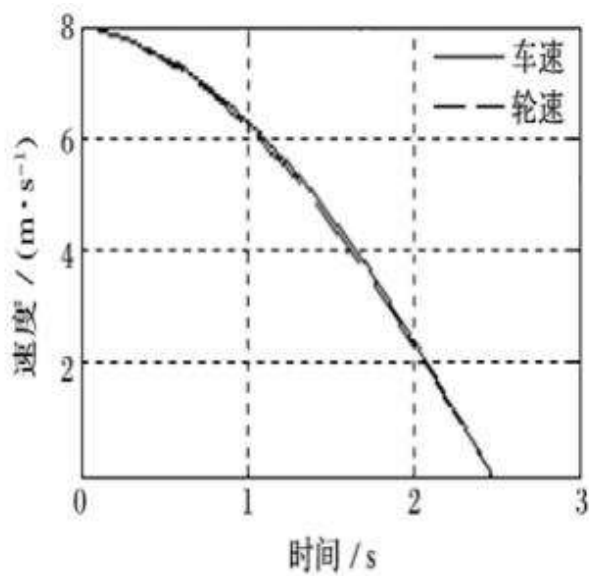

Figure 9: Braking Distance of Electric Locomotive

Fig. 10 shows the simulation results of the wheel speed and speed of the mine electric locomotive under the 3 kinds of control. We can see from Figure10, the braking time no motor vehicle antiskid braking control of the longest is 2.76 s; the logic threshold control of motor vehicle braking time and braking time is 2.47 s; the motor vehicle PID control is the shortest, 1.02 s. By contrast, the use of the anti-skid braking system allows the speed of the mine electric locomotive to fall to zero even faster during braking. In addition, when PID control is adopted, the brake can better control the wheel speed according to the requirements of the anti-skid braking system, so that the wheel speed and speed remain a certain difference, so as to achieve the best slip rate.



(a) no anti-skid braking control



(b) logical threshold control

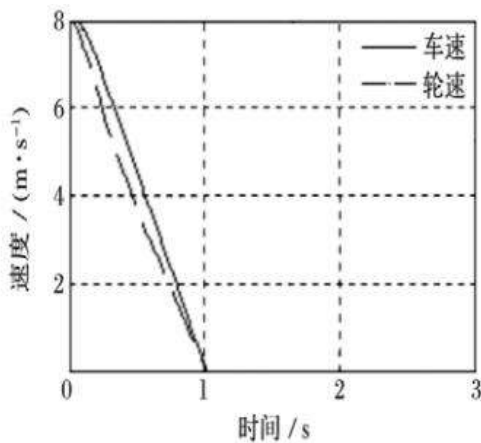

(c) PID control

Figure 10: Simulation Results of Wheel Speed and

Vehicle Speed

Fig. 11 simulation results of slip rate of mining electric locomotive under these 3 control algorithms. You can see from Figure 11, no anti-skid brake control and the logic threshold control of mine electric locomotive, the slip rate increases slowly with the change of time, did not reach its ideal value; and the slip of mine electric locomotive PID control rate increased rapidly to the ideal slip rate is about 20%, and can fast stabilize. It can be seen that the PID controlled mine electric locomotive can better control the slip ratio and achieve the best braking efficiency when braking.

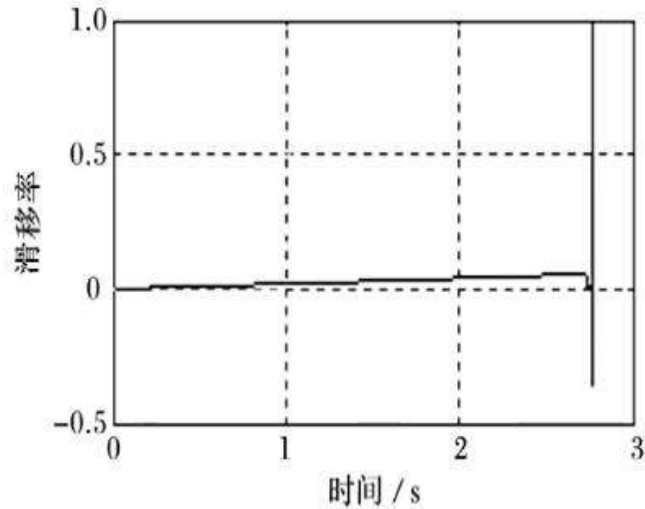

(a) no anti-skid braking control

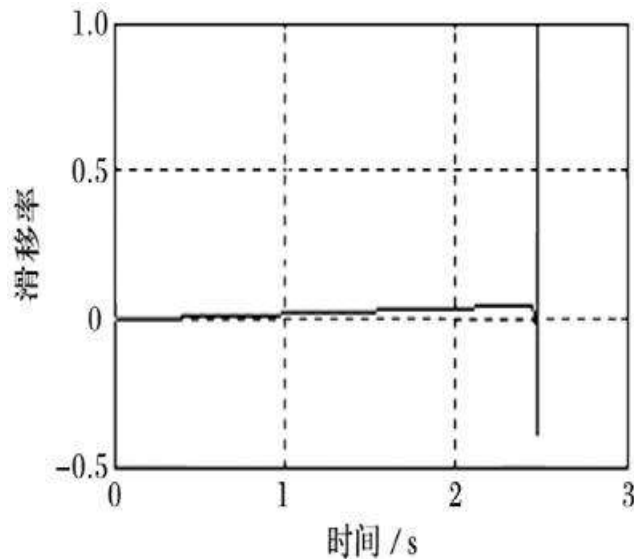

(b) logical threshold control

Figure 11: Slip Rate Simulation Results

Figure 9 ~ 11 of the simulation results show that the non motor vehicle antiskid braking control is more obvious than a motor vehicle brake anti-skid control distance, braking time is long, it is necessary to install anti-skid control system in motor vehicle. When choosing the control algorithm of the anti-skid system, we should not only consider the control algorithm in simulation, but also consider the advantages and disadvantages of the control algorithm in the practical application.

VI.CONCLUSION

In order to improve the efficiency and safety of the coal mine, it is necessary to improve the braking system and skid control system of the mine electric locomotive. This paper designed a new scheme of the brake,

hydraulic disc brake used in motor vehicle design, anti-skid braking system. The braking system modeling simulation using MATLAB/Simulink antiskid braking control, motor vehicle logic threshold control and PID control of the simulation results demonstrate the feasibility of mine electric locomotive used PID control of anti-skid braking system and effective, provide ideas for the study of anti-skid braking system of mine electric locomotive.

REFERENCES

- [1] Zhuan X, Xia X. Speed regulation with measured output feedback in the control of heavy haul trains [J]. *Automatica*, 2008,44(1):242-247.
- [2] Zhuan X, Xia X. Optimal scheduling and control of heavy haul trains equipped with electronically controlled pneumatic braking systems [J]. *Control System Technology, IEEE Transactions on*, 2007,15(6):1159-1166.
- [3] Muhammad N.S.Hadi. Neural networks applications in concrete structures. *Computers and Structures*, 2003,(81):373-381.
- [4] BU Fanping, TANHanshue. Pneumatic Brake Control for Precision Stopping of Heavy-Duty Vehicles [J]. *Transaction Control Systems Technology*, 2007, 15(1): 53-64.
- [5] HIRC-O Yamazaki, MASAONagai, TAKAYOSHI. A Study of Adhesion Force Model for Wheel Slip Prevention control [J]. *JSME International Journal*, 2004, 47(2): 496-501.